



FIT-OUT SOLUTIONS



General Overview

SINCE 1973...

The EAE Group started its journey in the electrical industry in its factory located in Gungoren, Istanbul when the EAE Elektrik Corporation was established in 1973. As a result in the increasing demand for output capacity production was moved to its cutting edge factory in Ikitelli, Istanbul in 1995. The Corporation has expanded its manufacturing area further by putting into service its factories established in Esenyurt, Istanbul in 2007. In 2015, cable tray systems factory in Gebze commenced its operations.

All of the companies in the EAE Group were established with 100% national capital. The product development of all of the EAE Group of companies is carried out by the in-house R&D departments.

The EAE Group performs its manufacturing operations in accordance with ISO 9001 quality, ISO 14001 Environment and ISO 27001 information security standards. Compliance of products with world standards is certified as a result of tests conducted by KEMA (DEKRA) and CESI laboratories.

FIT-OUT SOLUTION

This department, established in early 2014 within EAE Elektrik A.Ş., in the EAE Corporate Group, offers innovative and technological alternative solutions particularly for indoor electrical installations and "Fit-Out" applications. Products, such as the following, fulfilling the Fit-Out solutions and requirements are offered within the scope of our department's approach towards the indoor installation requirements with the logic of "package and complete solution";

- "FL/FLD" Indoor Busbar Trunking Systems (32 A)
- "SMART" Equipped Office Automation Socket Blocks and Backbone Channel
- "DABLINE" Raised Underfloor Power Distribution Busbar (63 - 80A)
- "NDK" New Range Under-screed and Raised Floor Cable Ducts, Junction Box and Outlet (Socket) Boxes
- "MINI" Mini Series Pop-up and IP66 Outlet Boxes
- "KYS" Group Lighting Circuits Energy Distribution and Control Systems (25-40-63A)
- "WSB" Wall Type Modular Socket Boxes
- "MULTIBOX" Socket Combination and Circuit Breaker Boxes

The Fit-Out department offers full technical support and will work with the client to ensure the correct product selection for their project.

Furthermore, all sorts of special product design and manufacturing required for your Fit-Out solution and requirements are realized by the expert engineers of our department.

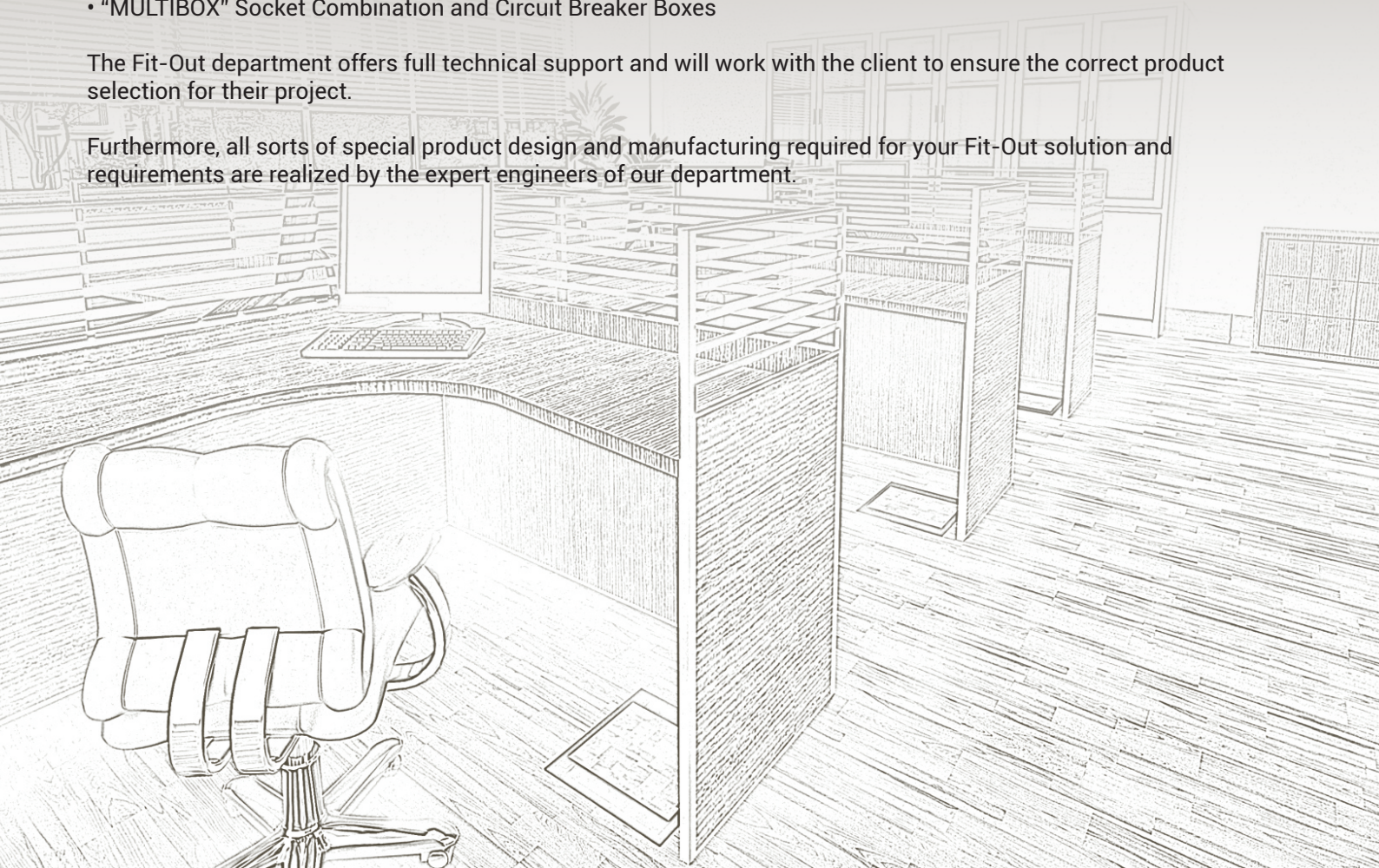



SM-DEC I

SM-DEC 6

SM-LUX II

SM-STD I

SM-FLEX CABLE ORGANIZER

E-LINE KY-S

BLONA

SM-DEC 7

SM-IN I

NDK-MINI

NDK-MX I

DAB LINE





MULTIBOX

Ekabin

KNX

E-LINE WSB

E-LINE FL/FLD

FIT-OUT SOLUTIONS

E-LINE FL / FLD

Indoor Busbar Tray Systems (32A)

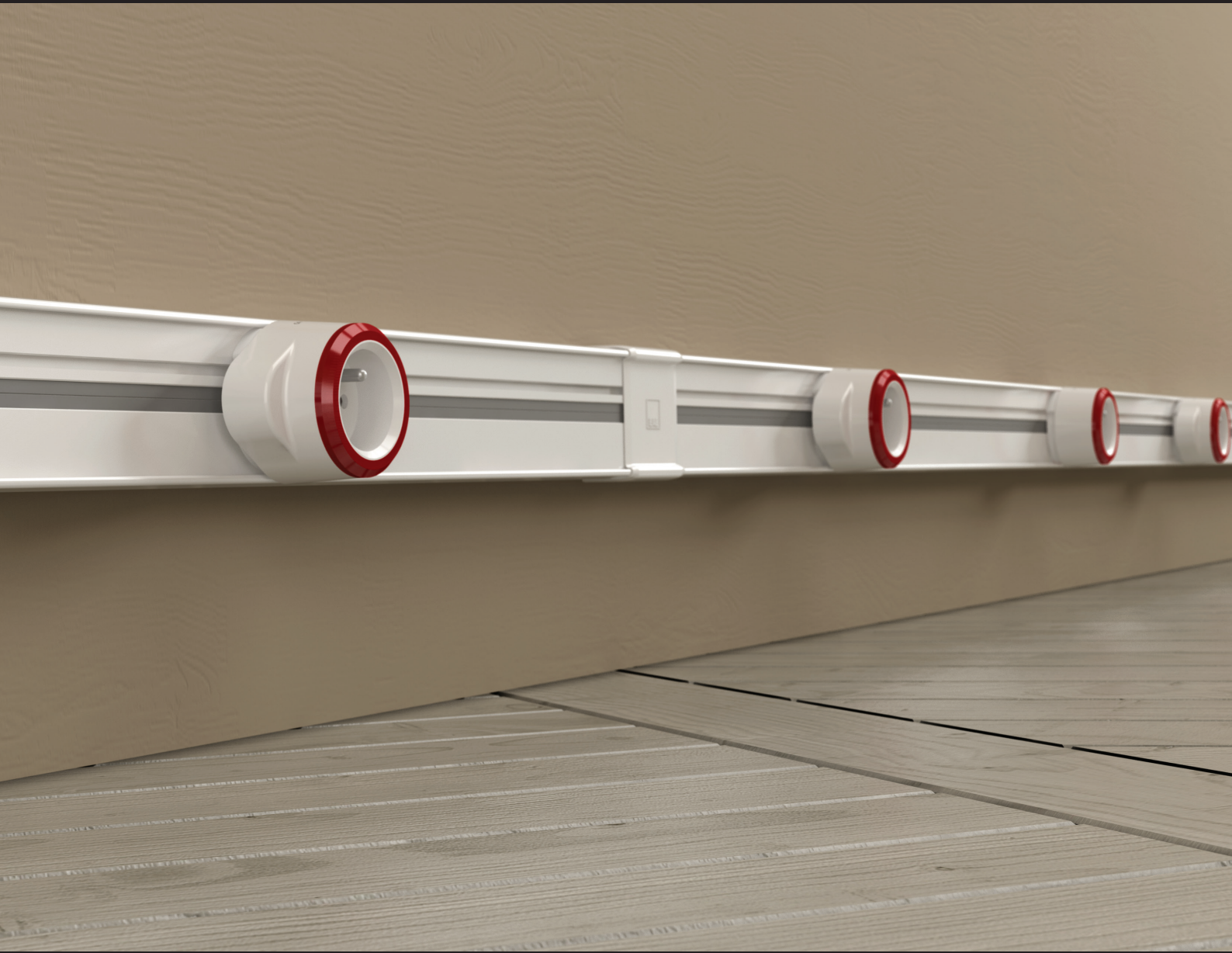

E-LINE FL/FLD Aesthetic, reliable, functional and flexible structure eliminating cable mess...

E-LINE FL/FLD Indoor Busbar Trunking Systems

Easy and convenient for safe power use, without the need for cabling at each desired and required location in working and living spaces such as offices, workshops, stores, markets, hospitals, laboratories, airport and business centres.

Absolutely no need for any additional cabling.

Thanks to its brackets, it can be easily mounted on any structure and surface and offers plain, simple and practical solutions for Mains and/or UPS socket requirements.

Custom designed sockets with an aesthetic structure have the characteristics of being installed in any desired spot without the need for any hand tool.

Manufactured in accordance with IEC 61439-6 standard with superior manufacturing technologies and tested accordingly. Certified by DEKRA and TSE.

Conductors protected against finger contact and dust (IP2XB), socket structure with lock mechanism preventing the removal of the sockets while the plugs are inserted ensures a safe use environment.

The standard colour is white with lengths of 1m. and 2m. and can be easily cut and subjoined at the mounting location. Cable section is available in separate and compact structure for structural cabling (data and telephone). Cable section in compact structure offers a mounting facility without using socket mounting plates for the sockets in modular structure (45x45, 22,5x45mm) such as data, telephone, TV, etc.

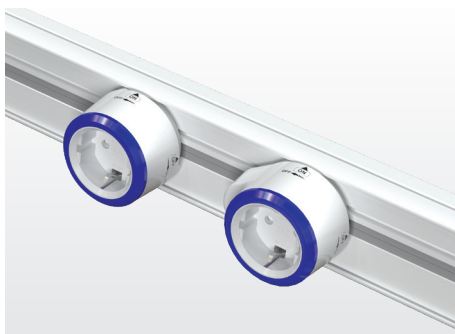

Aesthetic Design

- Flawless and aesthetic design attuning with all kinds of environments.
- Flexible structure with a large range of accessories making it easy to meet the clients' requirements.

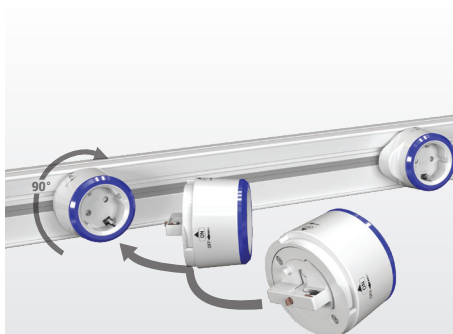

Functional Structure and Safety

- Single Phase Circuit; 3 Conductors, L/N/PE
- Mains and UPS sockets have a built in locking system that cannot be removed when the plug is inserted.

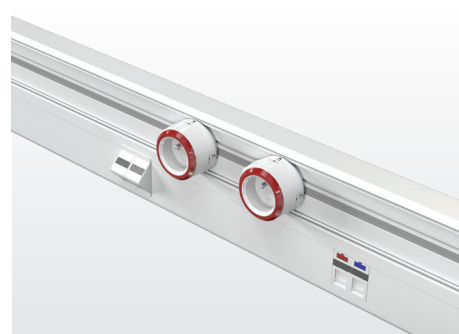

Fuse Protected Sockets

- 16A, 250V, 2P+E socket options with German and French standards for mains and UPS.
- Local protection with easy accessible 2-16A-250V cartridge (cylindrical) fuse.

FIT-OUT SOLUTIONS

E-LINE SMART

Office Automation Socket Blocks able to be Equipped



E-LINE SMART Flexibility, ergonomics and performance F in living spaces...

Ready to use products fully equipped with power, (mains/UPS), data, telephone and telephone charging and multimedia sockets for work stations, meetings and presentations offer exact solutions for your requirements.

Offers a flexible structure suitable to give a choice of outlet arrangements to meet special combination requests.

Ensures facilitation and flexibility thanks to its anodised aluminium coating choices of black or white, large choice of frame options, cable entry options of knockouts, bushed, or snap-on socket type, and versions with screwless connectors.

All of the plastic components are polycarbonate (PC) and with halogen-free property and in non-combustible class V0 in accordance with UL-94 standard.

SM-STD I (free type), SM-STD II (fixed standing type), SM-LUX I (free type), SM-LUX II (fixed standing type), SM-IN I (recessed rectangular type), SM-DEC 7 (column type) and SM-DEC 6 (mini-column type) production of 8 different models and structures with the desired features is possible. The SM-Std B model also allows you to complete the installation of sockets and wiring thanks to its empty structure which is produced in 8 different capacity options from 6 modules to 20 modules.

Flexible structure compliant with working environments and project solutions, large range of accessories to offer aesthetic solutions with superior performance.



Aesthetic and Complete Safe Design

- Product option equipped with custom design miniature circuit breaker (MCB) or residual current device operated circuit breaker with overcurrent protection (RCDBO).



Cable Entry and Finishing

- Standard manufacturing with blasted type lateral cover.
- Cable entry options such as interlocking type screwless connector or bushed type.

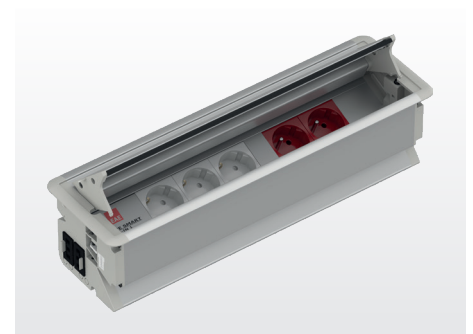

Flush Mounted Type Frame Structure

- Aesthetic and functional solutions flush mounted on the desk in rectangular and cylindrical structure.

FIT-OUT SOLUTIONS

DABLINE

Raised Underfloor Power Distribution Systems (63-80A)



DABLINE Do not let cable tray and complex, risky and messy cablings, junctions and tough applications upset you...

For plain, easy and fast solutions minimizing the risk under the raised floor without requiring cable tray, cabling, junction box and connector...

Manufactured in accordance with IEC 61439-6 standard and granted with certificates of conformity issued by DEKRA and TSE.

2 different products are available with the current-carrying capacities of 63A and 80A and offering an output range of 13A-32A. Ensures high corrosion resistance with painted (RAL 7038) and sheet metal frame structure.

Tin plated electrolytic copper conductors offer excellent power transmission.

Plastic parts are in V2 flame resistant class in accordance with UL 94, compliant with 960 °C glow wire test conditions in accordance with IEC 60965 with halogen-free property.

IP 55 protection class safeguards the system against water and humidity. Single bolt jointing technology guarantees earth continuity and gives a secure and substantial joint.

The ultra low profile structure enables Dabline with the outlet plug fitted to be used under a raised floor of only 10cm.

The copper conductors are tin plated and fully insulated along their whole length. All contact surfaces are silver plated, this ensures reliable and flawless operation.

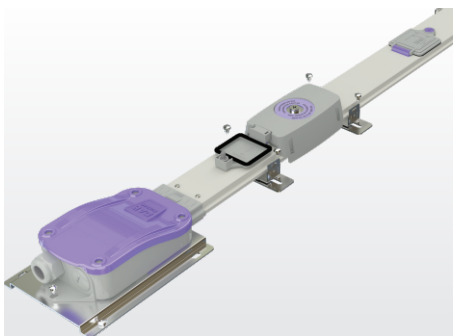

Lilac Series

Yellow Series

Blue Series

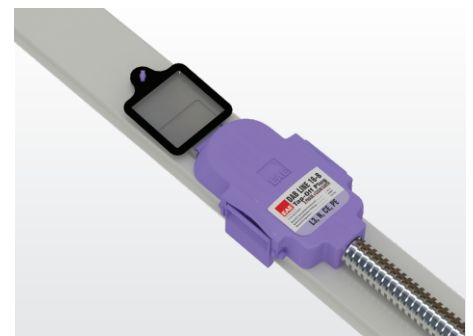
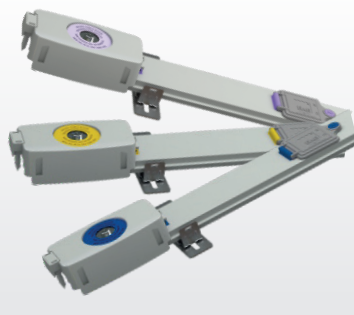

Aesthetic, Rich and Flexible Design

Standard manufacturing in different lengths of 120, 240 and 300 cm.
Possibility of having 9 outlets in standard busbars of 300 cm.
Manufacturing of custom lengths in desired sizes.

Functional Structure

3-phase System, 4 Conductors, 3L/N/PE, Yellow Series.
3-phase Clean Earthed System, 5 Conductors, 3L/N/CE/PE, Lilac Series.
Single-phase, Clean Earthed Dual System, 5 Conductors, 2L/2N/CE/PE (Frame), Blue Series.

Safety

Cabled or cable free outlet plugs with options of 13A, 16A and 32A and flexible conduit protection
Cylindrical (cartridge) fuse and MCB type miniature circuit breaker option.
Combined residual current device operated circuit breaker with overcurrent protection (RCDBO) use option at outlet boxes.

FIT-OUT SOLUTIONS

E-LINE N-DK

Under-screed and Raised Floor Cable Ducts, Junction Box and Outlet (Socket) Boxes



E-LINE N-DK Options of a new design modular, aesthetic and compact socket box for under-screed and raised floor...

Manufacturing in accordance with EN 50085-2: 2008 standards, granted with certificates of conformity issued by DEKRA and TSE.

MX Model New Range Outlet Box; offers a strong, comfortable and aesthetic options with 3 different models both for under-screed and raised floor applications.

CX Model New Range Compact Socket Box offers strong and heavy-duty options with 6 different models both for under-screed and raised floor applications by means of its galvanized sheet frame and sheet reinforced stainless cover structure.

New Grommet Multi-Functional Socket Box offers substantial alternative solutions both for underscreed and raised floor applications by means of its ingenious design with its plastic frame, capacity of 6 modules and suitable for use with miniature circuit breaker (MCB) options or residual current device (RCD).

IP-55 Grommet Water-Proof Socket Box offers a strong and aesthetic solutions both for under-screed and raised floor applications by means of its plastic frame, capacity of 4 modules, stainless steel frame and cover structure in humid and wet environments.

Plastic parts are in V2 flame resistant class in accordance with UL 94, compliant with 960 °C glow wire test conditions in accordance with IEC 60965 with halogen-free property.

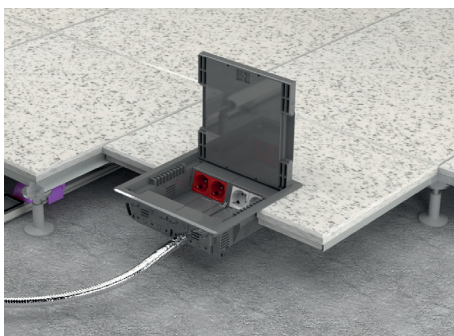

Flexibility in Use and Robust Structure

Outlet capacity options of 8, 16 and 24 modules. Design is suitable for use in raised floor applications with the addition of the bottom cover.

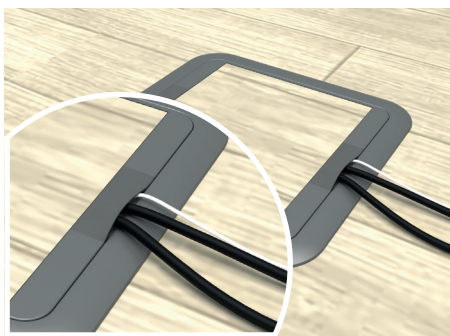

Robust and Aesthetic Outlet Window

Aesthetic structure ensured by elastic cover "cable clamp" in robust and ergonomic structure designed for various cable diameters.

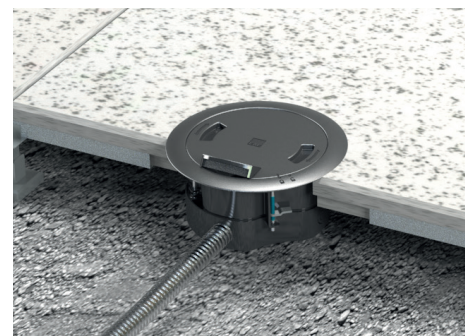

Multi Purpose Use

Along with its socket box function the unit's adaptable design enables flexible conduit to be connected to the (MCB and/or RCD) protection units either underfloor or flush mounted in a raised floor.

FIT-OUT SOLUTIONS

E-LINE MINI

Mini Series Pop-up and IP66 Outlet Boxes



E-LINE MINI New, aesthetic, compact and mini-solutions for working desks and under-screed sockets...

The pop-up range of products, designated as P-Box 3M and P-Box 6M, offer ergonomic and aesthetic options for both desktop and under-screed applications thanks to their stylish design and ease of use.

The outlet box which provides IP66 protection due to its water and dust-proof design, designated R-Box, offers robust, reliable and stylish solutions in humid, wet and dusty environments with a capacity of 6 modules, plastic housing, plastic back box with stainless cover and frame.

The outlet box which provides IP66 protection due to its water and dust-proof design, designated C-Box, offers robust, reliable and stylish solutions in humid, wet and dusty environments with a capacity of 6 modules, stainless cast zinc alloy cast housing and metal back box.

The IP66 range of products provides a safe environment in use with two-stage hinged cover and locking mechanisms that prevent cables from getting crushed.

It is suitable for use in many environments such as residences, shopping malls, airports, factories, workshops, management buildings, offices, hotels, hospitals, health centres and sports centres.

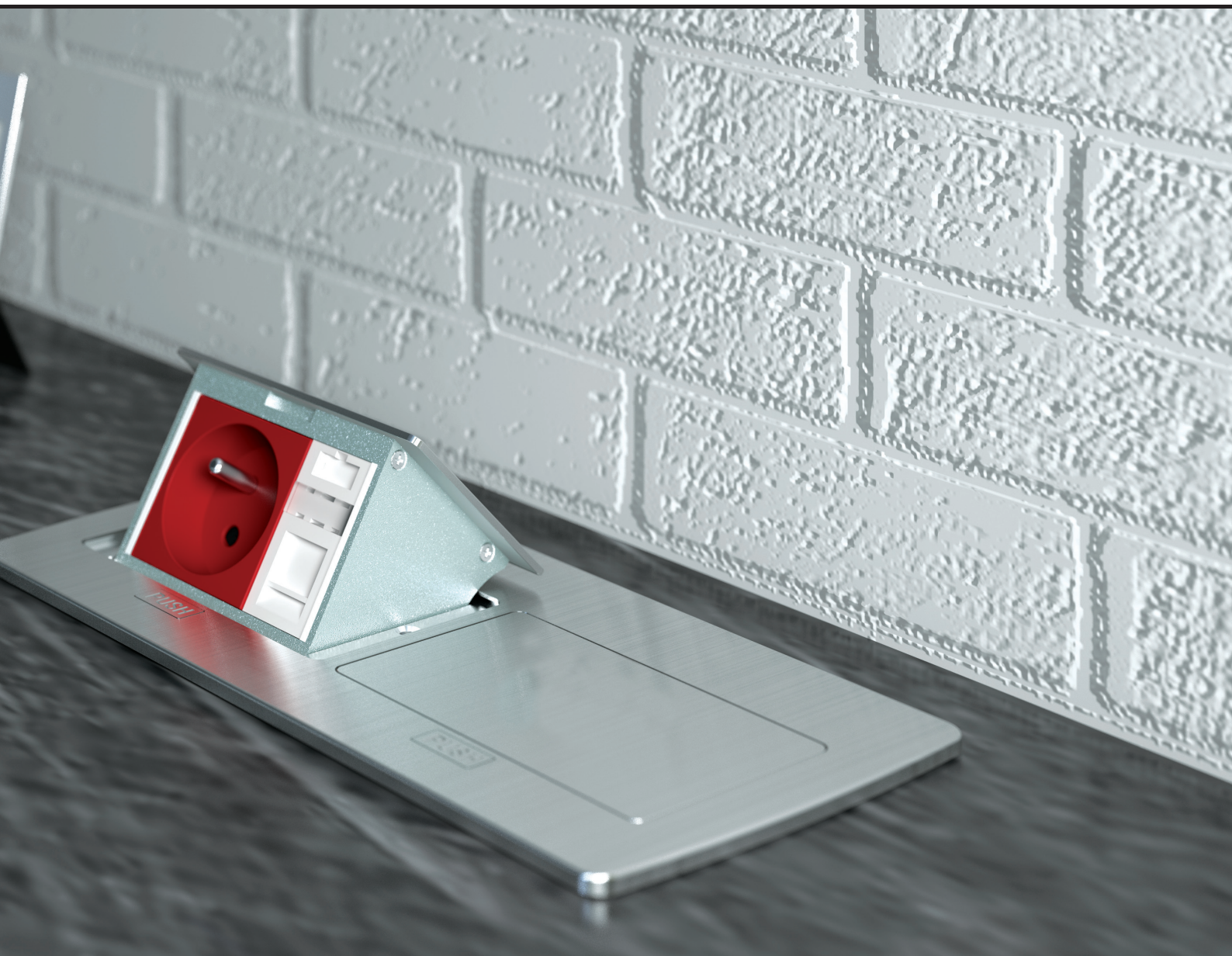

Aesthetic and Easy to Use

- Socket plates suitable for modular type power, data, telephone and multimedia sockets
- Suitable to use with desktop, raised floor and under-screed applications
- 3 and 6 module options
- Metal backbox
- Cast zinc alloy body, stainless covers

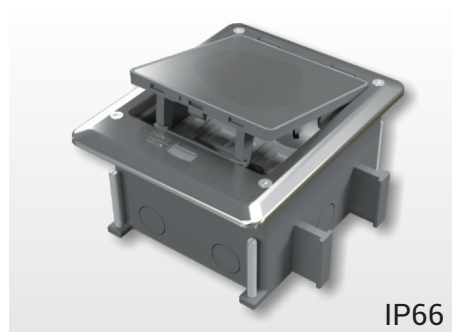

Durable and Robust Design

- Socket plates suitable for modular type power, data, telephone and multimedia sockets
- Backbox with pipe entry and housing suitable to use with under-screed and raised floor applications
- Special locking mechanism to prevent cables from being crushed

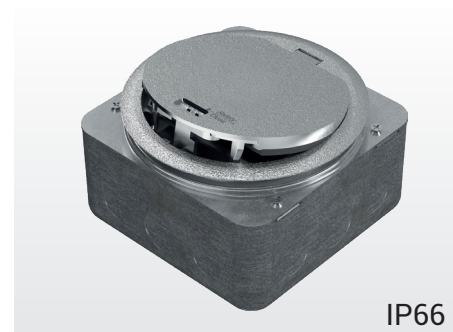

Durable, Robust and Aesthetic Design

- Socket plates suitable for modular type power, data, telephone and multimedia sockets
- Backbox with pipe entry and housing suitable to use with under-screed and raised floor applications
- 6 module socket capacity
- Special locking mechanism to prevent cables from being crushed
- Zinc alloy cast body, stainless steel covers

FIT-OUT SOLUTIONS

E-LINE KY-S

Lighting & Low Power Distribution Systems 25-40-63A

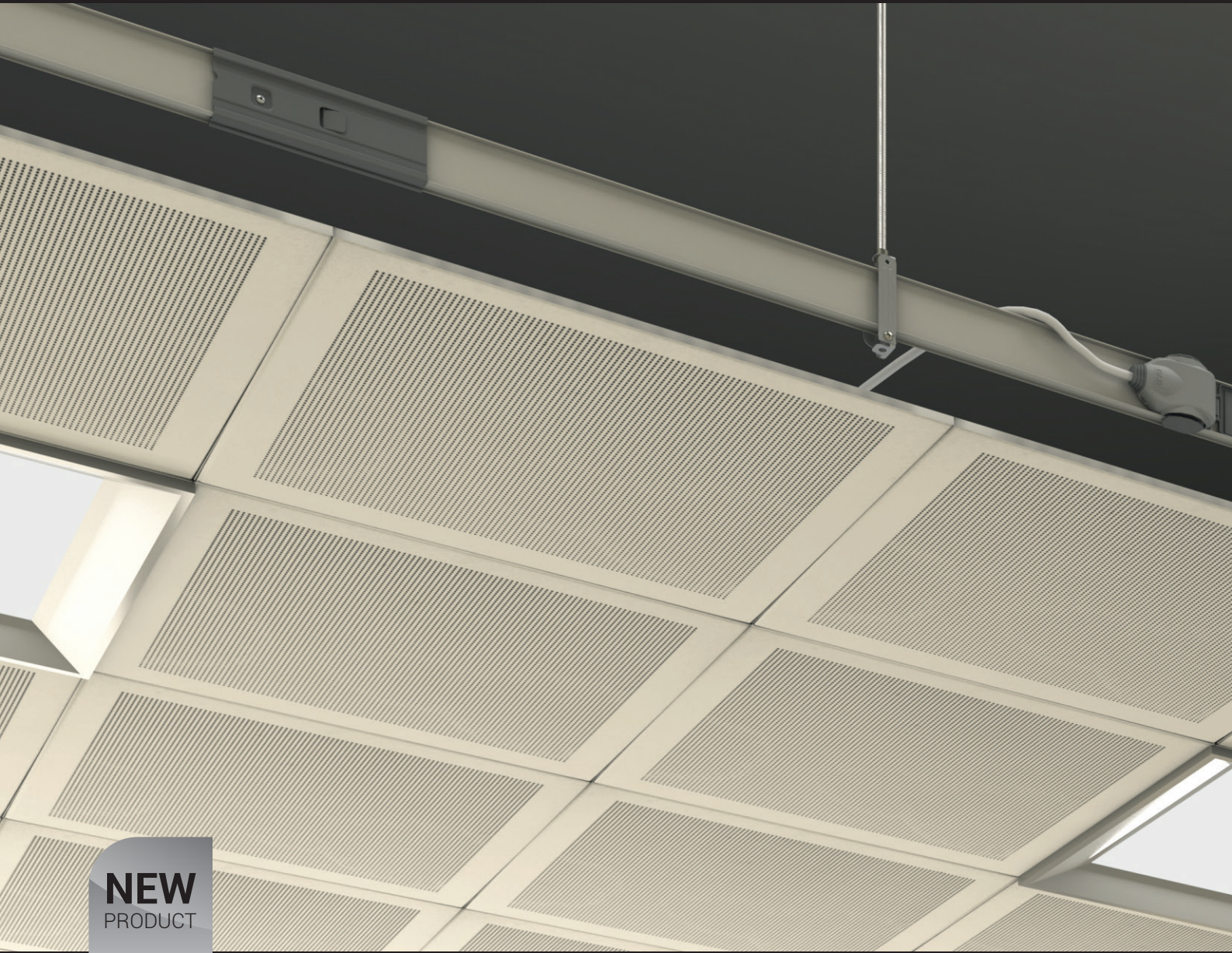

NEW
PRODUCT

E-LINE KY-S E-Line KY-S Busbar Duct Systems are used in all types of building electrical installations with energy requirements of 25-40-63A.

The features of 10A and 16A output plugs and 32A output boxes make them suitable for powering lighting and socket circuits as well as small electrical machines and devices.

The protection class is IP55 when the current receiving window covers are closed. It provides a convenient, easy, and simple infrastructure for the automation of lighting fixtures with DALI ballasts and for supplying emergency circuits.

KY-S busbars are manufactured in standard lengths of 1m and 3m. The busbar body is made of pre-galvanized sheet metal and can optionally be produced in RAL7038 painted color.

Output plugs are designed in three different types:

- "Simple-Wired"
- "Cartridge (Cylindrical) Fuse-Wireless"
- "Terminal-Wireless"

Output boxes are designed in two different types suitable for Miniature Circuit Breakers (MCB):

- "Suitable-Empty"
- "Cartridge (Cylindrical) Fuse-Wireless"

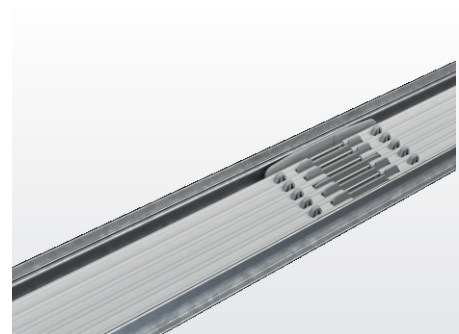
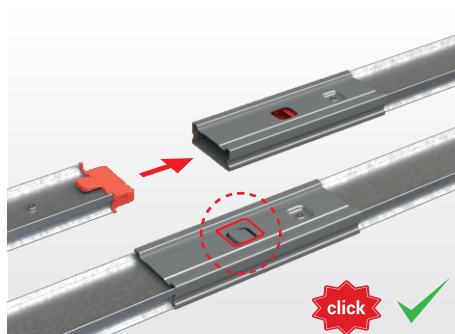
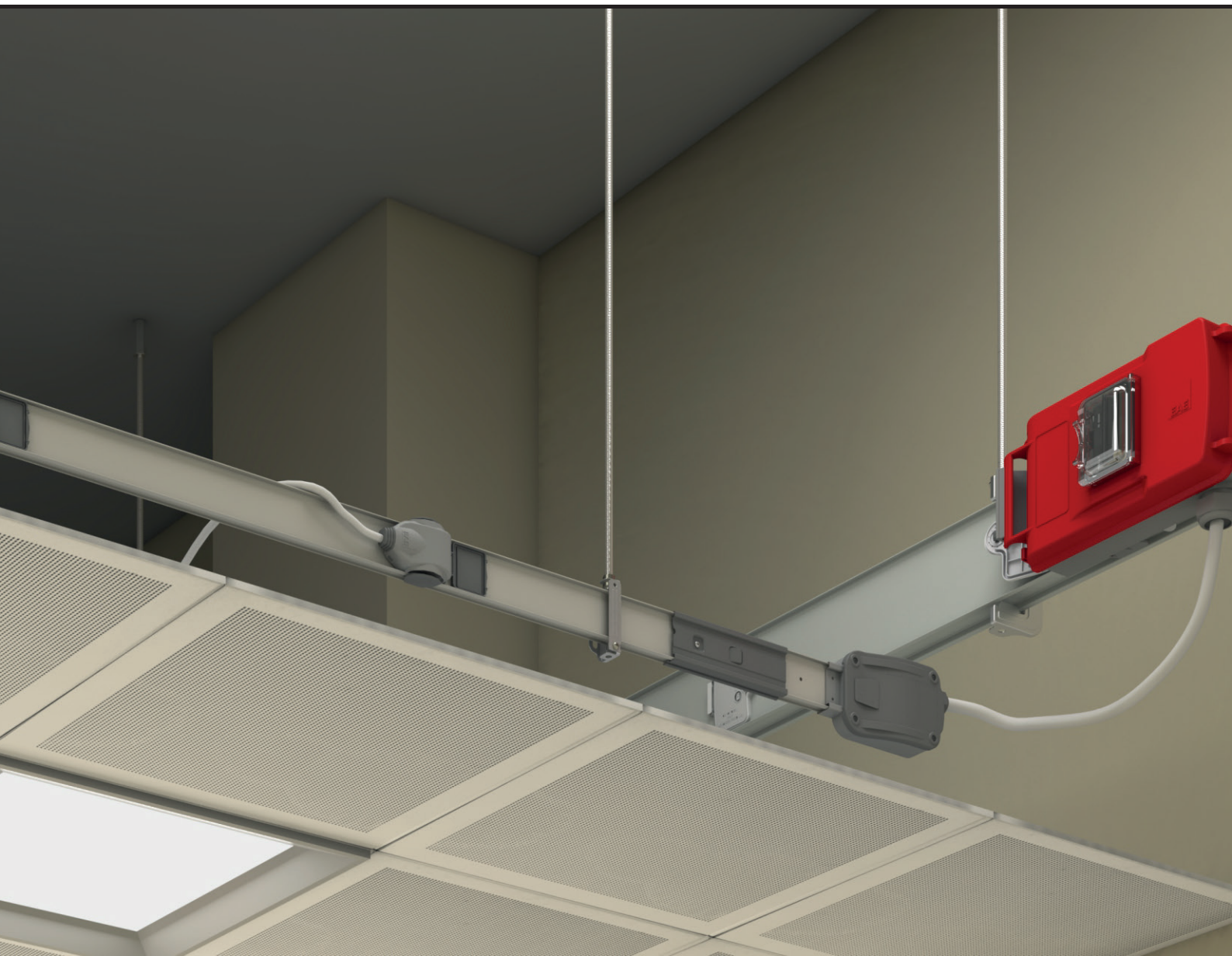

Output Plugs and Boxes

- The output plugs of KY-S busbar systems are designed with different address structures to prevent misuse and electric shock.
- All plugs and boxes are manufactured to be fitted to the busbar in only one direction, which prevents incorrect phase utilization.

Quick, Easy, and Safe Installation

- Mechanical and electrical continuity is achieved in a single motion by sliding the joint structure with silver-plated spring contacts into each other.
- No bolts need to be tightened to secure the locking.
- The joint structure, which prevents sagging and flexing, does not require any processing or tools for installation.

Full Length Insulation

- The busbar conductors are covered with full-length flame-retardant insulation material.
- Even if the outer body is damaged by heavy external impacts, full protection against direct contact is ensured for human safety.

FIT-OUT SOLUTIONS

E-LINE WSB

Wall Type Modular Socket Boxes



E-LINE WSB Wall-mounted outlet box W solutions combine aesthetic and functional design with safety...

Wall-mounted outlet boxes, designated WSB, offer alternative solutions with a capacity range from 4 to 16 modules.

They offer easy and safe options with casings suitable for use of modular type power, data, telephone and multimedia outlets along with a modular and click-insert design.

The original design offers a safe, unique and controllable environments for operation and maintenance due to transparent cover of MCB, RCD or RCBO box.

The product provides seamless and perfect solutions on all kinds of wall surfaces due to its aesthetic and modular backbox, which is compatible with the product housing for flush mounting and surface mounting applications.



Easy Concealed Mounting

- Different design options with the capacity from 4 modules to 16 modules.
- Self-positioning and convenient mounting clips
- An aesthetic top cover compatible with the housing.
- Installation without backbox for plasterboard type surfaces.



Easy Surface Mounting

- Different design options with the capacity from 4 modules to 16 modules.
- Backbox, equipped with knockouts, compatible with the housing and suitable for cable inlets.
- An aesthetic top cover compatible with the housing.

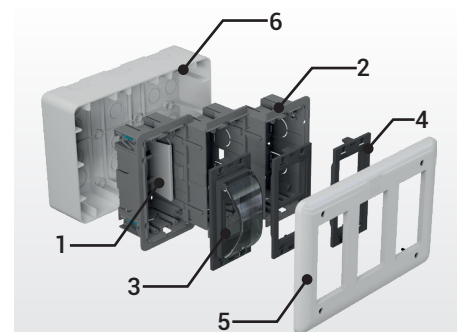

Modular and Click-Insert Design

1. MCB/RCD box (PA6) with DIN rail
2. Modular, interlaced type socket case
3. MCB/RCD plate with transparent cover (PA6 + PC)
4. Modular socket plate. (PA6)
5. Modular socket box, front cover. (ABS)
6. Backbox for surface mounting.

FIT-OUT SOLUTIONS

E-LINE MULTIBOX

Socket Combination and MCB Box



E-LINE MULTIBOX MULTIBOX is a multi-purpose modular structure distribution box combining mcb, rcds and sockets for power distribution in factories, offices and working environments. The Multibox range can be supplied equipped or non-equipped.

Offers IP-44 and ABS frame as a special modular structure, 230/400V AC operating voltage and current ratings up to 80A.

Can be fitted with CEE 16A - 240v cover type panel sockets (schuko) and industrial sockets up to 63A 400v 13 modules for residual current device (RCD) and/or miniature circuit breaker (MCB) offer extensive use facilities with breakable plate padlockable plug-in option and transparent covered section. As an option the "input module" can be added with a neutral trip and a padlockable padlock safety switch.

Special compartment for use with an MCB or cartridge fuse in the input module safety switch, 4 modules, with a breakable plate, transparent cover and DIN rail.

Neutral (N) and earth (PE) busbars are available in standard in add-on modular structure and connecting terminals.

When used with covered connector module and transparent covered mcb module, it offers an option that the alternative bottom covers can be used as a "mcb and distribution box".

Standard products are available as a complete combination box including the unequipped box, socket mounted box and switch material and cabling and customized manufacturing can be done depending on the requirement and requests.





Unequipped Boxes

• Socket Combination Box

16 different Unequipped Box option with 9 different front cover version for socket mounting.

• MCB (Distribution) Box

5 different Unequipped Box option with 5 different bottom cover version for cable outlet. Flush-mounting option.



Combination Boxes with Sockets Mounted

Excluding switch material and cabling, 36 different standard socket combination options with 9 different front cover versions only with sockets mounted.

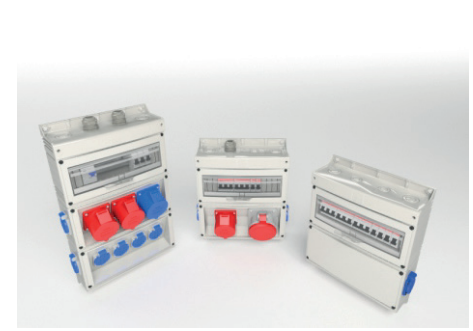

Fully Mounted Combination Boxes

Including switch material and cabling, 38 different standard socket combination option with 9 different front cover versions with sockets mounted.

FIT-OUT SOLUTIONS

LED Lighting Fittings



DECORATIVE LED LIGHTING

EAE Lighting is

- A Light Engineering Corporation,
- A Light Aesthetics Corporation.

Illuminance Grade;

Addressed for fulfilment of requirements related with seeing and modern working environments.

Visual Comfort;

An aspect required to be addressed for office solutions.

Solutions offered by EAE Lighting;

- High light outlet and optimum glare restriction,
- High energy efficiency – Thermodynamic management,
- Compliance with green building criteria – Technological infrastructure,
- Energy saving and short-term cost amortization,
- Appropriate luminous illuminance level
- Attractive ambient and high working performance are the parameters taken into consideration.

Advantages of LED Lighting Fittings:

- High lighting efficiency,
- Long life (60 thousand hours of service time, service life not requiring maintenance for over 10 years),
- Lower power consumption, accordingly lower heat emission,
- Positive contribution to air-conditioning costs.

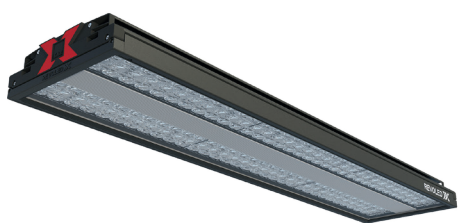

REVOLED-X

REVOLED-X, offering the optimum solution for the different needs of industrial facilities, is a reliable lighting solution for production facilities of various heights with its wide range of lumen packages, optical options developed for special applications, and luminaire efficiency.



BLOOM-S NG

BLOOM-S NG, with its clean lines, has a wide range of applications from hospitals to schools and from offices to retail stores. It is energy-efficient with advanced LED technology. BLOOM-S NG, standing out for being both environmentally friendly and economical, provides a long-lasting lighting solution, increasing your energy efficiency and reducing your costs.



DOWNLED IP65 Ø177

DOWNLED IP65 not only meets the required IP rating for damp environments but is also suitable for outdoor and under-eaves areas. Thanks to its deeply positioned light source and opal diffuser, it does not cause glare.

FIT-OUT SOLUTIONS

KNX Commercial and Industrial Building Solutions / KNX Smart Home and Residence Solutions



KNX commercial and industrial building solutions, which can be expanded unlimitedly and can be configured flexibly to meet all customer expectations, are supported by a large ecosystem independent of the main supplier thank to the use of open system protocols.

EAE Technologies has been a member of KNX manufacturer and an authorized training centre since 2012

Advantages

- Easy control over an architectural visual
- Access over web browser
- Instant image formation over AutoCAD file
- Individual display of fixtures (DALI)
- Status reporting of emergency lighting fixtures
- Alarm reporting over SMS and e-mail

<p>Use energy when needed</p>	<p>Use energy as necessary</p>	<p>Take advantage of the solar energy to the max</p>	<p>Achieve energy savings up to 40</p>
--------------------------------------	---------------------------------------	---	---





Take control of your living spaces with KNX smart home and residence systems. More security and comfort are at your disposal...

KNX smart home and residence systems, facilitating integration in living spaces, offer aesthetic integrity, comfort beyond limits and energy saving all together with user friendly and plain interface...

All family members can manage the devices such as lighting, heating-cooling and curtain/blinds with ease, activate burglar alarm, watch the cameras and can talk to the incoming guests via intercom. Moreover, you can easily fulfil your needs such as taxi, valet service or SPA reservation.

The Valesa touch panel, the most important component of the KNX smart home and residence system, fulfils your entire needs from a single point by assisting you to enjoy comfort in your home.

sAdding value to your ambient aesthetics with its sleek design through a single touch, the Valesa panel becomes an indispensable member of your home with its functionality.

Enjoy living in comfort with the KNX smart home system perfected with Oria thermostat, switches and sockets.



FIT-OUT SOLUTIONS

E-CABINET E and E-CABINET O Series Wall-Mounted Installation Cabinets



E-CABINET

E-Cabinet E Series Wall-Mounted Type Fit-Out Cabinets

E-Cabinet E Series Fit-Out Cabinets are particularly designed for applications of indoor electrical installations of buildings such as shopping centres, hotels and hospitals. Design allows use of DIN-rail type devices.

Use Area	: Indoor, dry environments
Protection class	: IP 55, glazed door IP 40
Mounting Type	: Wall type, erected type
Bearing construction	: 2 mm galvanized sheet
Paint	: Epoxy - polyester powder paint
Colour	: Standard RAL 7035
Glass	: 4 mm tempered safety glass
Operating temperature	: +5°C, +40°C
Operating relative humidity:	90% at +20°C
Complying Standards	: 50% at +40°C IEC 61439-1, IEC 62208 IEC 60529, IEC 62262



E-CABINET

E-Cabinet O Series Wall-Mounted Type Electrical Cabinet

E-Cabinet O Series Electricity Cabinets are designed as enclosures for electrical equipment for general use.

Use Area	: Indoor
Protection class	: IP 66
Mounting Type	: Wall type
Paint	: Epoxy - polyester powder
Colour	: Standard RAL 7035
Operating temperature	: -5°C, +40°C
Operating relative humidity:	90% at +20°C 50% at +40°C
Operating environmental conditions class	: E32, but maximum relative humidity is 90% and the lowest temperature is -5°C, in accordance with EN 60721 -3 -3.
Complying Standards	: IEC 61439-1, IEC 62208 IEC 60529, IEC 62262

FIT-OUT SOLUTIONS

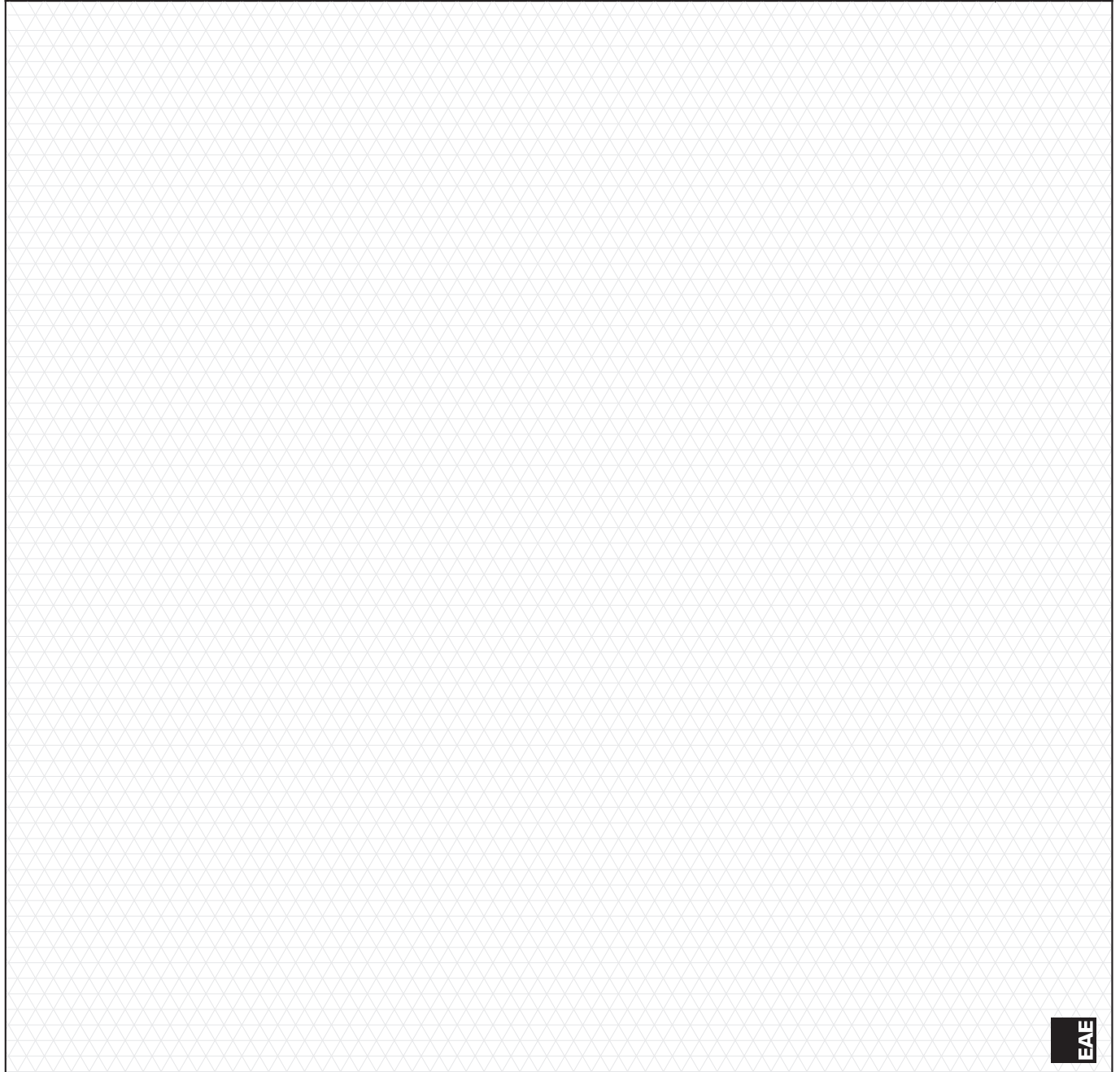
Component List				
Item No	Component	Quantity		
				
			Company :	
			Project :	
Project No:		Prepared by		
Name :		Date :		
Signature :				

Please duplicate this page for your own use.



PRODUCT TYPES



BUSBAR ENERGY DISTRIBUTION SYSTEMS



CABLE TRAYS



TROLLEY BUSBAR ENERGY DISTRIBUTION SYSTEMS



INDOOR SOLUTIONS



SUPPORT SYSTEMS



EAE Elektrik A.S.
Head Office
Akcaburgaz Mahallesi,
3114. Sokak, No:10 34522
Esenyurt - Istanbul - TURKEY
Tel: +90 (212) 866 20 00
Fax: +90 (212) 886 24 20

EAE DL 3 Factory
Busbar
Gebze IV Istanbul Makine ve Sanayicileri
Organize Bolgesi, 6. Cadde,
No: 6 41455 Demirciler Koyu,
Dilovası - Kocaeli - TURKEY
Tel: +90 (262) 999 05 55
Fax: +90 (262) 502 05 69

EAE Aydınlatma
İkitelli Organize Sanayi Bolgesi
Ziya Gokalp Mahallesi,
Eski Turgut Ozal Caddesi No: 20 34490
Başakşehir - Istanbul - TURKEY
Tel: +90 (212) 413 21 00
Fax: +90 (212) 549 37 90

EAE Elektroteknik
İkitelli Organize Sanayi Bolgesi
Ziya Gokalp Mahallesi,
Eski Turgut Özal Caddesi No: 20 34490
Başakşehir - İstanbul
Tel: +90 (212) 549 26 39
Fax: +90 (212) 549 37 91



Catalogue 25-En. / Rev. 09 0 Pcs. 05/06/2024
S.S.

EAE has full right to make any revisions or changes on this catalogue without any prior notice.

